

2

1

ELECTRICAL CHARACTERISTICS

CENTER FREQUENCY: 1950 MHz NOM
 3 dB BANDWIDTH: 60 MHz MIN
 INSERTION LOSS: 1.8 dB MAX @ FO
 VSWR: 1.5:1 TYPICAL
 REJECTION:
 47 dBc MIN @ 2110-2170 MHz

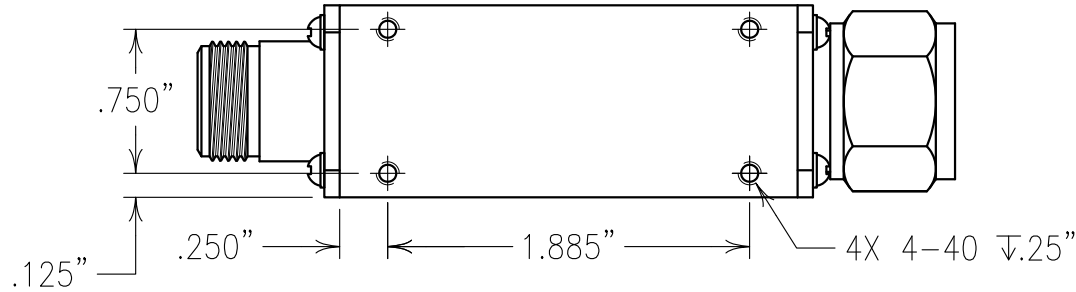

COPY

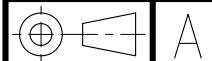
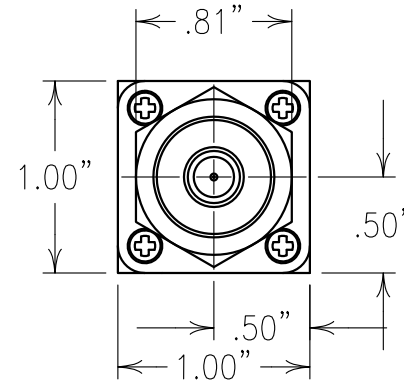
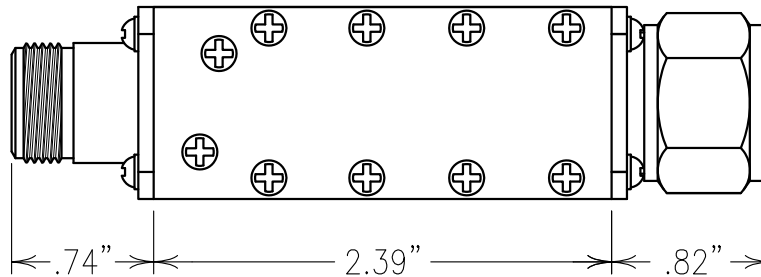
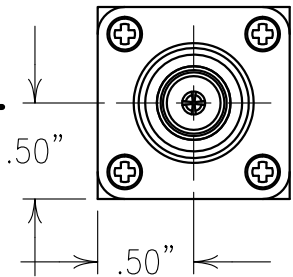

Confidential and Proprietary information of ComNav Engineering Inc. Do Not Duplicate or Use Without Permission. ComNav Engineering Inc. claims Copyright in this document as of the Creation, last revision, and last updated dates. All Rights Reserved.

ENGLISH / METRIC ENGLISH	CHECKED BY				
TOLERANCES UNLESS OTHERWISE SPECIFIED MACHINED SURFACES TO BE 125/10 OR BETTER REMOVE ALL BURRS	DRAWN BY PBF				
	ENGINEER KJR	II	06MAR14	KJR	DEV. INI. ISS. PER 3771
		REV	DATE	BY	DCN No. REMARKS

NOTES:

FILTER MUST BE ETCHED.
 FILTER IS ROHS COMPLIANT.

ENGLISH (INCHES) .XX ±.02 .XXX ±.010	METRIC (MM) .X ±.5 .XX ±.25	SCALE 1:1	APPLIC: CERAMIC COAXIAL FILTER
ANGLES ± 0° 30'	DATE 10MAR14	TITLE: 5BCR8BL-1950/C60-N/NP	SHEET OF 1 1

MATERIAL: ALUMINUM	DRAWING No.
FINISH: SILVER OVER COPPER WITH TARNA-BAN MILSPEC QQ-S-365	0L1412