

2

1

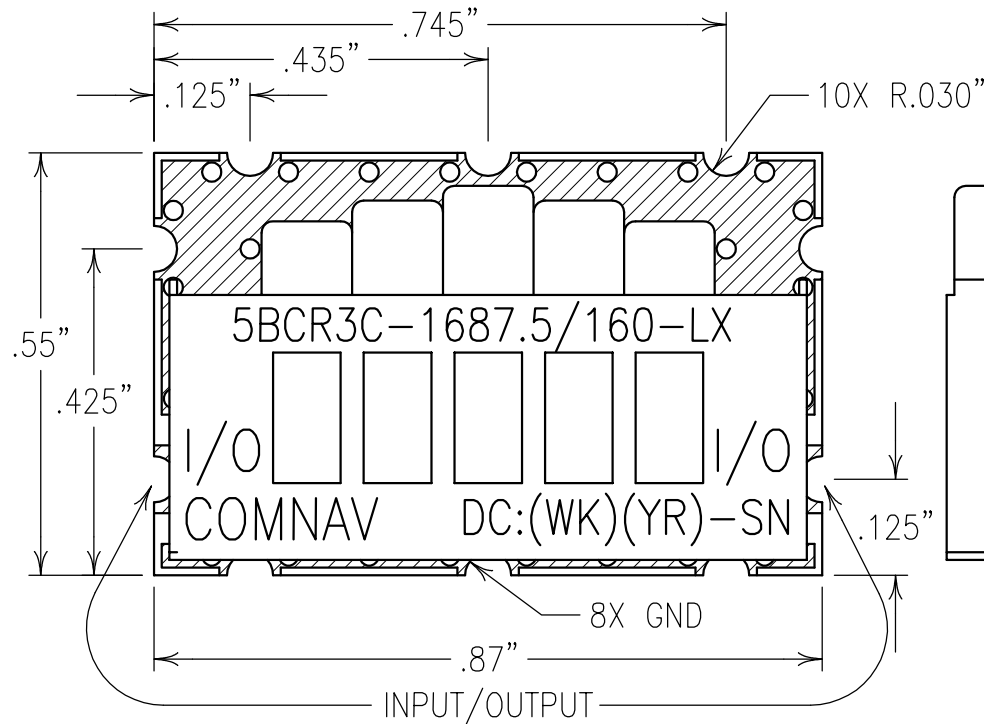
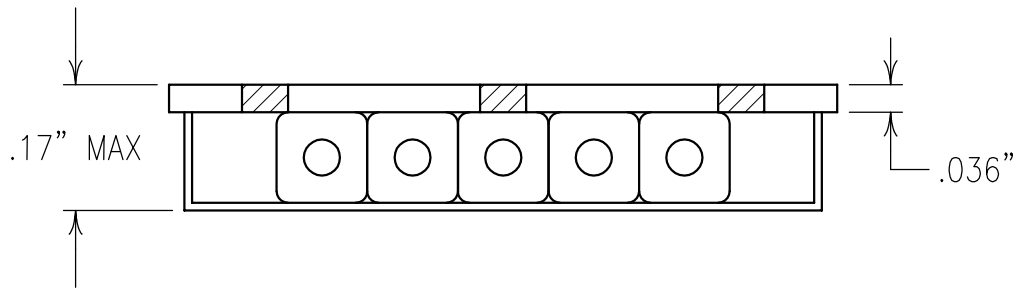

COPY

ELECTRICAL CHARACTERISTICS

CENTER FREQUENCY: 1687.5 MHz
 INSERTION LOSS: 5 dB MAX
 1 dB BANDWIDTH: 120 MHz MIN
 0.5 dB BANDWIDTH: 24 MHz MIN
 REJECTION: DC-1000 MHz: 60 dBc
 1000-1500 MHz: 40 dBc
 1875-2000 MHz: 40 dBc
 2375-3000 MHz: 50 dBc
 ABSOLUTE PB DELAY: 100 nSEC MAX
 PB DELAY VARIATION: 30 nSEC MAX
 POWER HANDLING: 0.1 W
 INPUT IMPEDANCE: 50 OHMS
 RETURN LOSS: 15 dB MIN
 OPERATING TEMP.: -40 TO +85°C

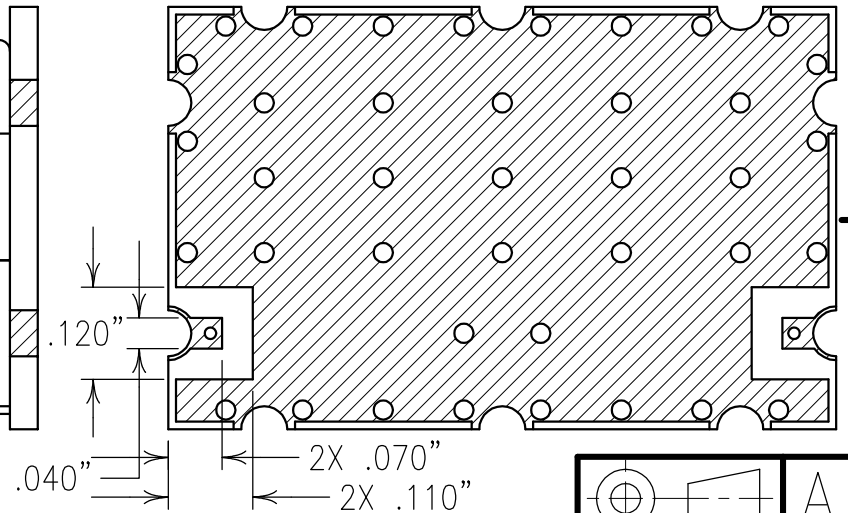

Confidential and Proprietary information of ComNav Engineering Inc. Do Not Duplicate or Use Without Permission. ComNav Engineering Inc. claims Copyright in this document as of the Creation, last revision, and last updated dates. All Rights Reserved.

NOTES:

RECOMMENDED ATTACHMENT METHOD:	TEMP.(°C)	MAX. TIME (SECONDS)
SILVER EPOXY OR REFLOW NOT TO EXCEED:	215	90
	230	60
FILTER IS ROHS COMPLIANT.	245	30
FILTER MAY BE LABELED OR ETCHED.	260	15

ENGLISH / METRIC ENGLISH	CHECKED BY				
TOLERANCES UNLESS OTHERWISE SPECIFIED TO BE 125 / OR BETTER REMOVE ALL BURRS	DRAWN BY PBF				
	ENGINEER KJR	II	28JAN09	KJR	DEV. INI. ISS. PER 3001
		REV	DATE	BY	DCN No. REMARKS
ENGLISH (INCHES) .XX ±.02 .XXX ±.01	METRIC (MM) .X ±.25 .XX ±.13	SCALE 4:1	APPLIC: CERAMIC COAXIAL FILTER		
ANGLES ± 0° 30'	DATE 28JAN09	TITLE: 5BCR3C-1687.5/160-LX			
	FINISH: BOARD: NI/AU JACKET: NI/SILVER RESONATOR: SILVER	DRAWING No. 0L0977	SHEET/OF 1 / 1		