

ELECTRICAL CHARACTERISTICS

3 dB CUTOFF:	2125 MHz NOM
PASSBAND:	1530-2070 MHz
REJECTION:	
60 dBc:	2320-2820 MHz
PASSBAND VSWR:	1.7:1
PASSBAND LOSS:	1.2 dB MAX
PASSBAND FLATNESS:	<0.75 dB

**COPY**

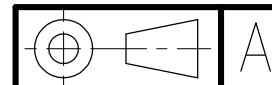
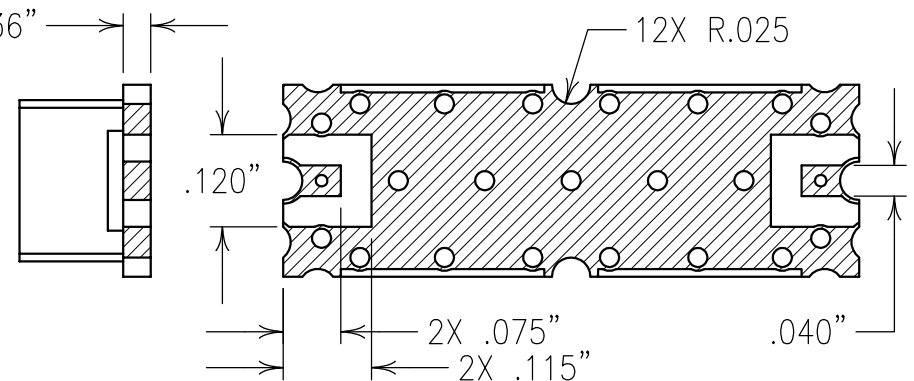
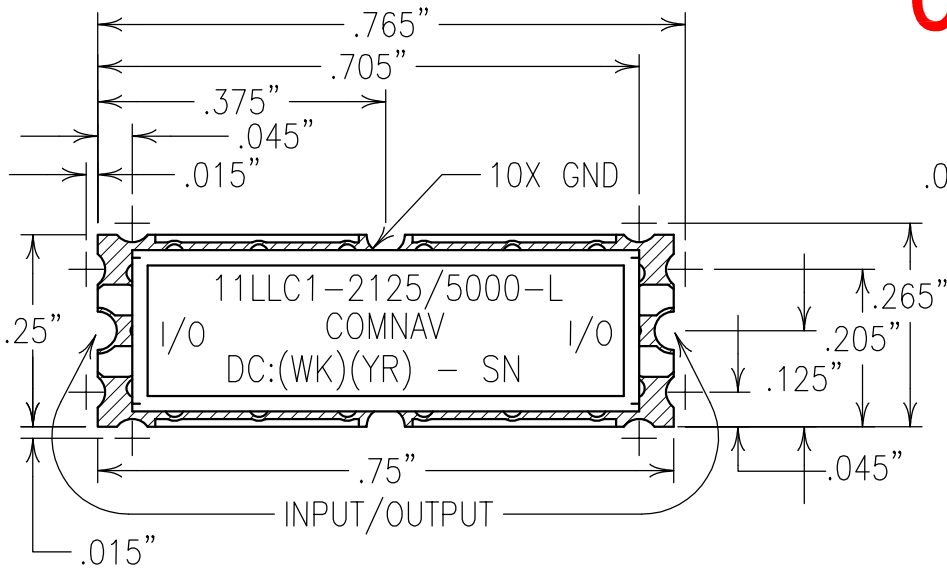
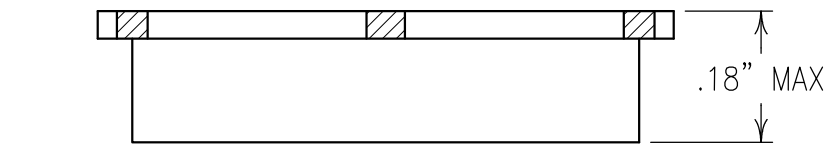

Confidential and Proprietary information of ComNav Engineering Inc. Do Not Duplicate or Use Without Permission. ComNav Engineering Inc. claims Copyright in this document as of the Creation, last revision, and last updated dates. All Rights Reserved.

NOTES:

RECOMMENDED ATTACHMENT METHOD:		
SILVER EPOXY OR REFLOW NOT TO EXCEED:	TEMP.(°C)	MAX. TIME (SECONDS)
	215	90
	230	60
FILTER IS ROHS COMPLIANT.	245	30
FILTER MAY BE LABELED OR ETCHED.	260	15

ENGLISH / METRIC ENGLISH	CHECKED BY				
TOLERANCES UNLESS OTHERWISE SPECIFIED TO BE 125 / OR BETTER REMOVE ALL BURRS	DRAWN BY PBF				
	ENGINEER KJR	II	24JUL08	KJR	DEV. INI. ISS. PER 2906
		REV	DATE	BY	DCN No. REMARKS
ENGLISH (INCHES) .XX ±.02 .XXX ±.01	METRIC (MM) .X ±.25 .XX ±.13	SCALE 4:1	APPLIC: CHIP AND WIRE FILTER		
ANGLES ± 0° 30'	DATE 14AUG08	TITLE: 11LLC1-2125/5000-L			
	FINISH: BOARD: NI/AU JACKET: NI/SILVER RESONATOR: SILVER	DRAWING No. 0L0926		SHEET/OF 1 / 1	