

COPY

ELECTRICAL CHARACTERISTICS	
CHANNEL 1 PASSBAND:	DC-473 MHz
CHANNEL 1 REJECTION:	
534-3,000 MHz:	50 dBc
CHANNEL 2 PASSBAND:	481-3,000 MHz
CHANNEL 2 REJECTION:	
DC-419 MHz:	50 dBc
CROSSOVER REJECTION (BOTH):	
477±1 MHz:	5 dBc
PASSBAND LOSS (BOTH):	2.5 dB MAX

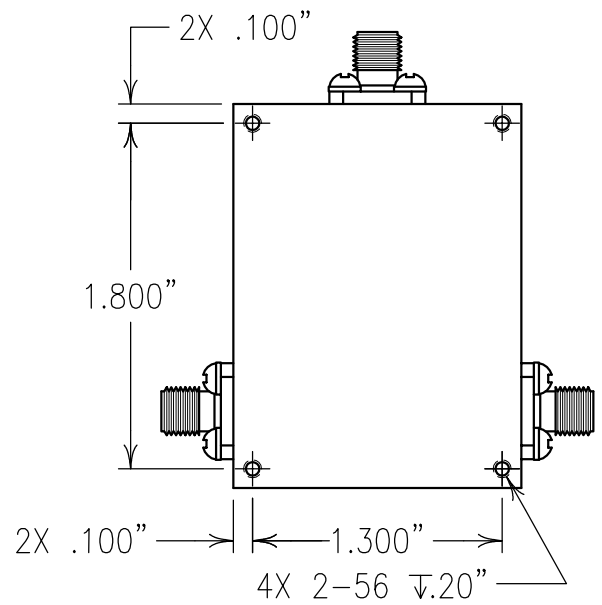
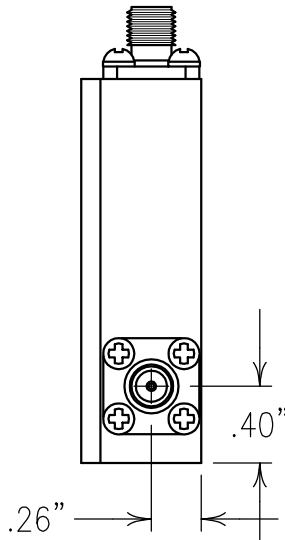
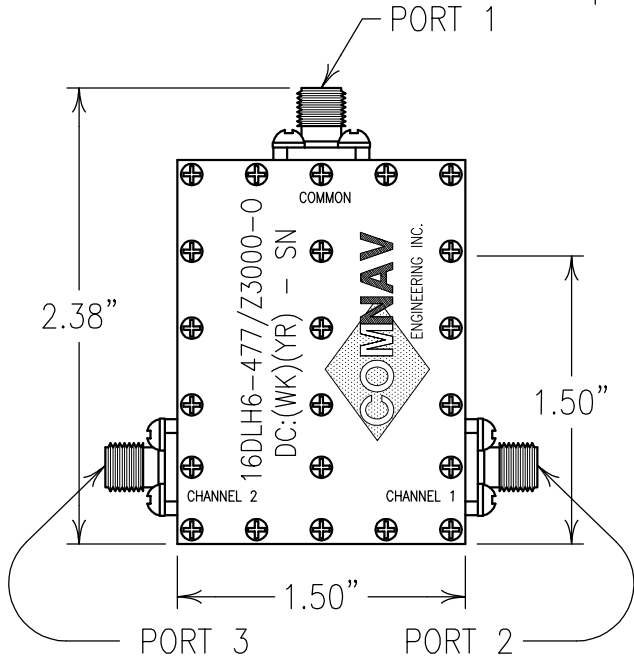

NOTES:

FILTER MAY BE LABELED OR ETCHED.
 FILTER IS ROHS COMPLIANT.

Confidential and Proprietary information of ComNav Engineering Inc. Do Not Duplicate or Use Without Permission. ComNav Engineering Inc. claims Copyright in this document as of the Creation, last revision, and last updated dates. All Rights Reserved.

ENGLISH / METRIC ENGLISH	CHECKED BY	B	14SEP09	MJG	DEV.	GEN. REV. PER 3113
TOLERANCES UNLESS OTHERWISE SPECIFIED	DRAWN BY	A	23JUL09	MJG	DEV.	GEN. REV. PER 3093
MACHINED SURFACES TO BE 125 / OR BETTER	ENGINEER	II	03JUL08	KJR	DEV.	INI. ISS. PER 2897
REMOVE ALL BURRS	MJG	REV	DATE	BY	DCN No.	REMARKS

ENGLISH (INCHES)	METRIC (MM)	SCALE 1:1	APPLIC: CHIP AND WIRE FILTER
.XX ±.01	.X ±.2	DATE 17SEP09	TITLE: 16DLH6-477/Z3000-0
.XXX ±.005	.XX ±.13		SHEET OF 1 1
ANGLES ± 0° 30'			

COMNAV ENGINEERING INC.	MATERIAL: ALUMINUM	DRAWING No. 0L0910
	FINISH: SILVER	