

VIBRATION: THE FILTER SHALL MEET ITS ELECTRICAL SPECIFICATIONS WHILE EXPOSED TO VIBRATION ACCORDING TO SECTION 514.5, PROCEDURE 1, CATEGORY 13 OF MIL-STD-810F (PROPELLER AIRCRAFT)
 SHOCK: THE FILTER SHALL MEET ITS ELECTRICAL SPECIFICATIONS AFTER EXPOSURE TO SHOCK ACCORDING TO SECTION 516.5, PROCEDURE 1 (FUNCTIONAL SHOCK - AIRCRAFT)

ELECTRICAL CHARACTERISTICS

CENTER FREQUENCY:	1350 MHz
1 dB BANDWIDTH:	20 MHz MIN
REJECTION:	
>40 dBc:	50-1280 MHz
>40 dBc:	1420-5000 MHz
>58 dBc:	1478-1497 MHz
INSERTION LOSS @ 1350 MHz:	5 dB MAX
FLATNESS (1340-1360 MHz):	0.5 dB
GROUP DELAY VARIATION ACROSS ANY 10 MHz OF 1340-1360 MHz PASSBAND:	5 nSEC
NOMINAL IMPEDANCE, I/O:	50 OHMS
RETURN LOSS ACROSS 1dB BW:	-14 dB
OPERATING TEMPERATURE:	-20 TO +80°C
STORAGE TEMPERATURE:	-20 TO +85°C
HUMIDITY, NON CONDENSING:	5-95%

COPY

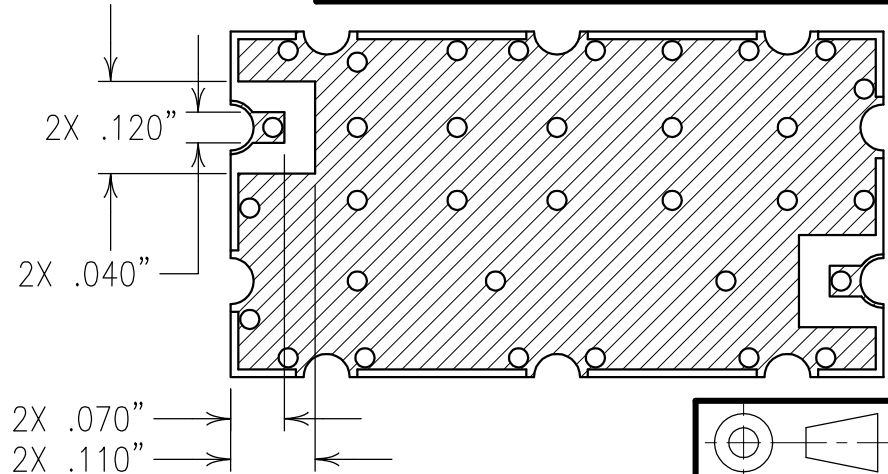
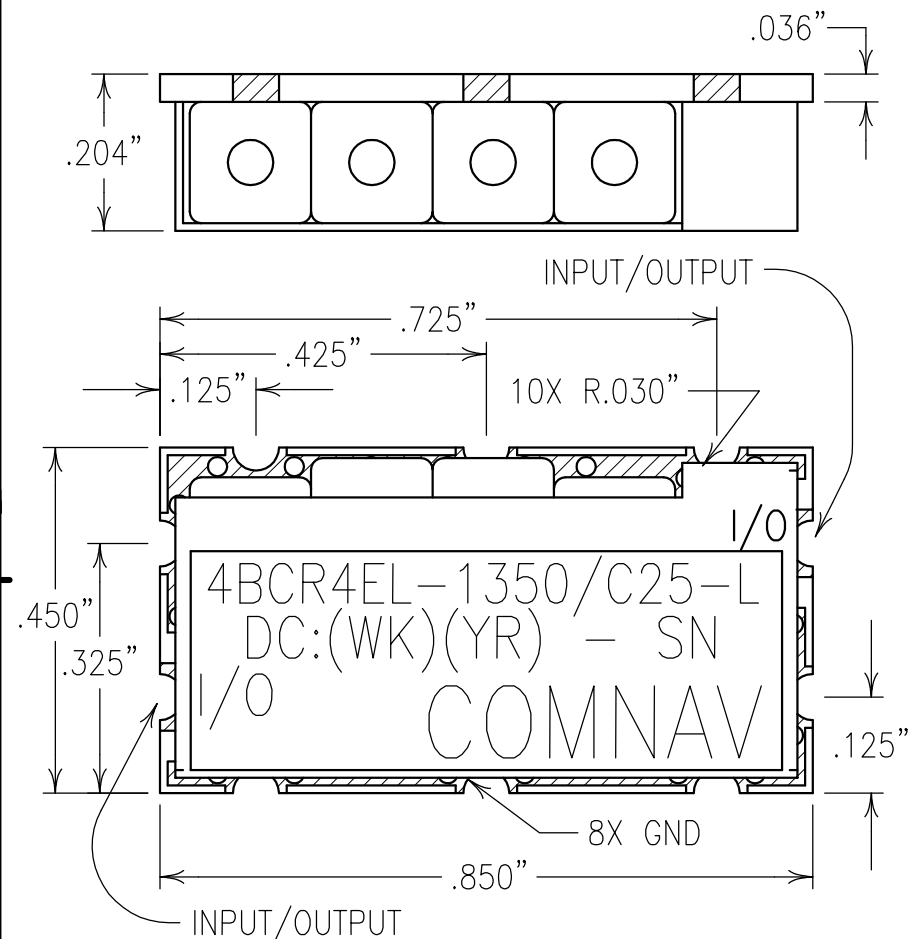

Confidential and Proprietary information of ComNav Engineering Inc. Do Not Duplicate or Use Without Permission. ComNav Engineering Inc. claims Copyright in this document as of the Creation, last revision, and last updated dates. All Rights Reserved.

NOTES:

RECOMMENDED ATTACHMENT METHOD:	TEMP.(°C)	MAX. TIME (SECONDS)
SILVER EPOXY OR REFLOW NOT TO EXCEED:	215	90
	230	60
	245	30
FILTER IS ROHS COMPLIANT.	260	15

ENGLISH / METRIC ENGLISH	CHECKED BY				
TOLERANCES UNLESS OTHERWISE SPECIFIED MACHINED SURFACES TO BE 125/100 OR BETTER REMOVE ALL BURRS	DRAWN BY PBF	A	02FEB08	KJR	DEV. GEN. REV. PER 2828
	ENGINEER KJR	II	18MAY07	KJR	DEV. INI. ISS. PER 2672
		REV	DATE	BY	DCN No. REMARKS
ENGLISH (INCHES) .XX ±.02 .XXX ±.01	METRIC (MM) .X ±.25 .XX ±.13	SCALE 4:1	APPLIC: CERAMIC COAXIAL FILTER		
ANGLES ± 0° 30'	DATE 07FEB08	TITLE: 4BCR4EL-1350/C25-L			
	FINISH: BOARD: NI/AU JACKET: NI/SILVER RESONATOR: SILVER	DRAWING No. 0L0736		SHEET/OF 1/1	