

COPY

ELECTRICAL CHARACTERISTICS

Tx:	408-409.5 MHz
Rx:	418.1-418.95 MHz
VSWR:	1.5:1
CO-CHANNEL ISOLATION	> 60 dB

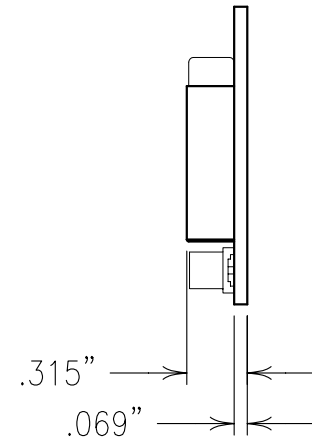

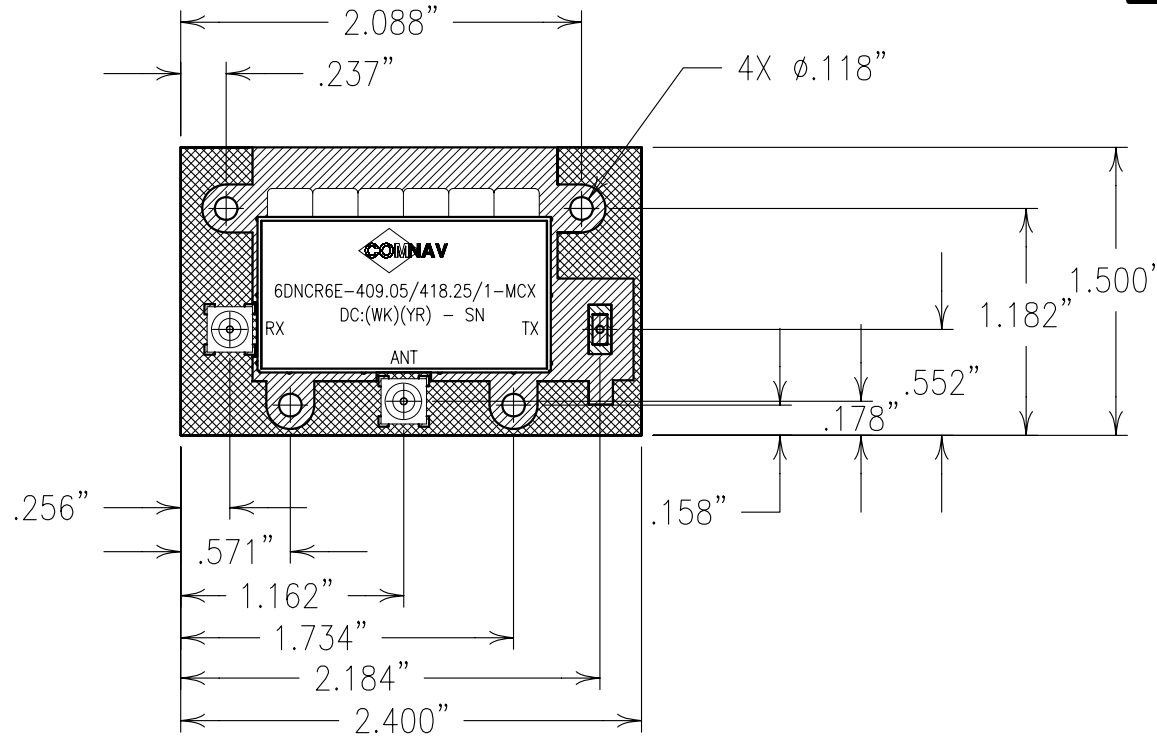

Confidential and Proprietary information of ComNav Engineering Inc. Do Not Duplicate or Use Without Permission. ComNav Engineering Inc. claims Copyright in this document as of the Creation, last revision, and last updated dates. All Rights Reserved.

NOTES:

RECOMMENDED ATTACHMENT METHOD: SILVER EPOXY
OR REFLOW NOT TO EXCEED AS INDICATED BELOW:

TEMP.(°C) MAX.TIME(SEC)

215	90
230	60
245	30
260	15

-  COPPER
-  SOLDER MASK
-  SOLDER MASK OVER COPPER

ENGLISH / METRIC ENGLISH	CHECKED BY				
TOLERANCES UNLESS OTHERWISE SPECIFIED	DRAWN BY				
MACHINED SURFACES TO BE 125 OR BETTER	ENGINEER	II	27DEC01	MJG	DEV. INI. ISS. PER 1811
REMOVE ALL BURRS	MJG	REV	DATE	BY	DCN No. REMARKS
ENGLISH (INCHES)	METRIC (MM)	SCALE	APPLIC: CERAMIC COAXIAL FILTER		
.XX ±.02	.X ±.50	1:1	TITLE: 6DNCR6E-409.05/418.25/1-MCX		
.XXX ±.010	.XX ±.25	DATE	DRAWING No. SHEET OF		
ANGLES ± 0° 30'		13FEB02	0L0386		1 1
	FINISH: BOARD: NI/AU JACKET: NI/SILVER RESONATOR: SILVER				